

RoHS Compliant

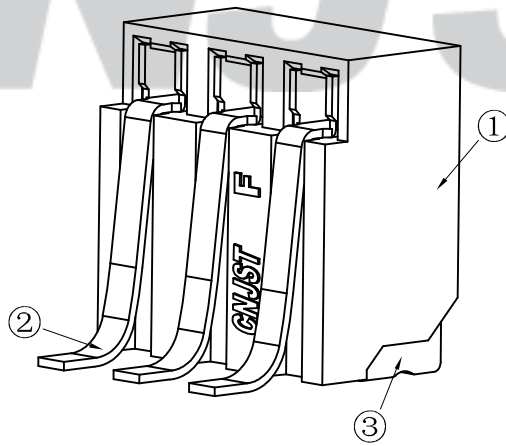
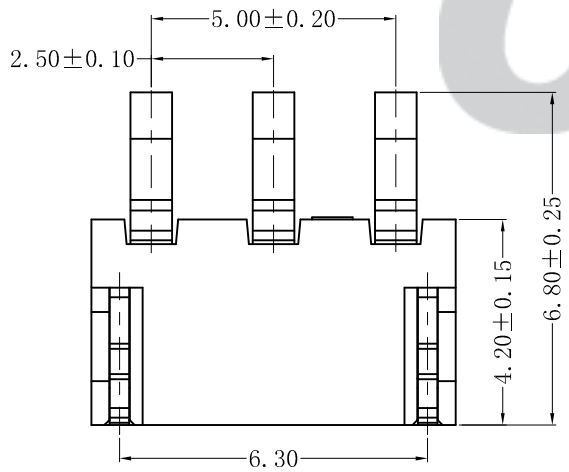
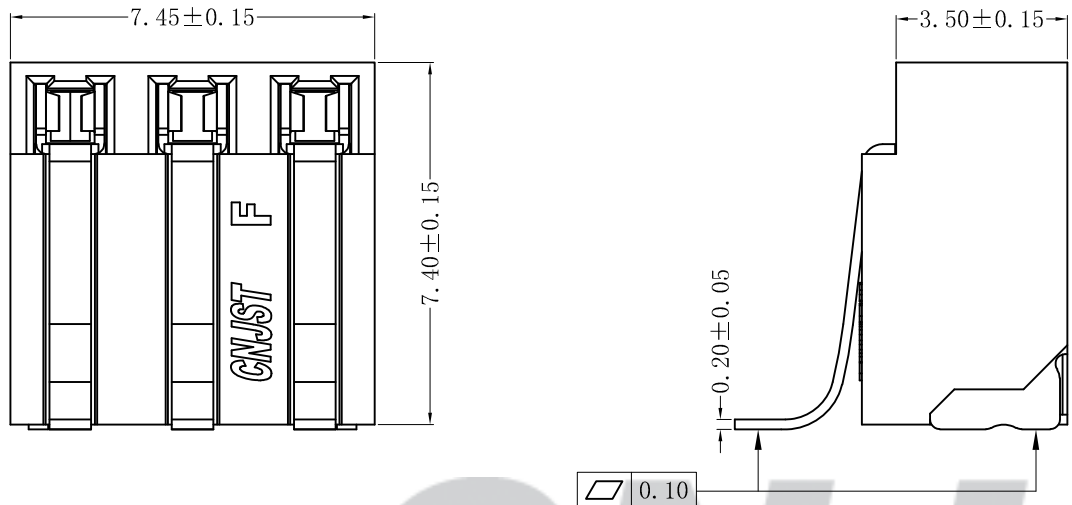

SPECIFICATION

- 1 Contact resistance: $\leq 20m\Omega$
- 2 Insulation resistance: $\geq 1000M\Omega$
- 3 Rated voltage: 125 V AC DC
- 4 Rated current: 1.0 A AC DC
- 5 Withstand Voltage: 1000V AC/minute
- 6 Temperature Range: $-25^{\circ}C \sim +85^{\circ}C$

ORDER INFORMATION:

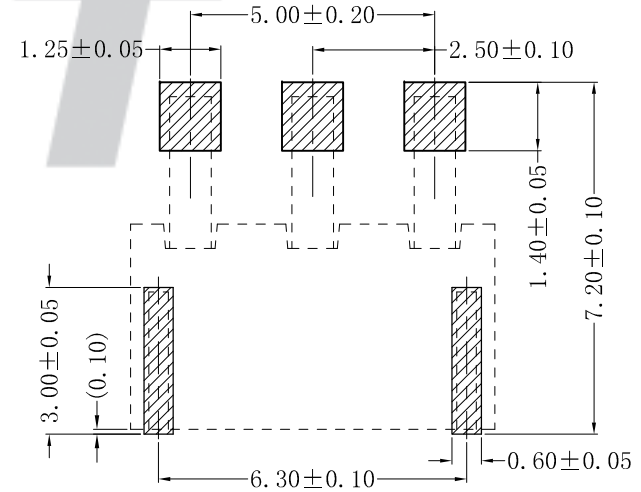
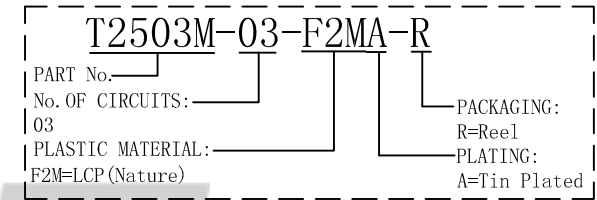

SUGGESTED PCB LAYOUT
(COMPONENT SIDE)

Tolerance X.X ±0.30 X.XX ±0.20 X.XXX ±0.10 Angle ±3.0°	CNJST 捷仕泰企业		Drawn: 王丽君 2023.08.25
	Model No.: T2503M-03-F2MA-R		Checked: 吴丹平
UNIT: mm	Model Name: 2.50mm Pitch 180° Wafer-SMT TYPE		Approved: 林旭芝
		SCALE: FULL	REVISION: C/O
			DWG NO. CNJST/GCCP-0468

REV.	DATE	DESCRIPTION	APPD.	NO.	DESCRIPTION	QTY	MATERIAL	PLATING/COLOR
				③	Solder Tabs	2	Brass	Tin Plated
C/O	2023.08.25	更新模板	王丽君	②	Contacts	3	Phosphor Bronze	Tin Plated
B/O	2021.07.02	NEW RELEASE	黄羨程	①	Insulator	1	LCP(UL94V-0)	Nature