

RoHS Compliant

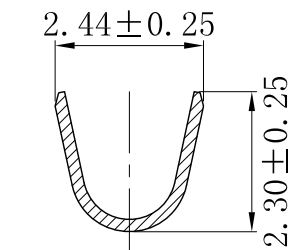

SECTION A-A

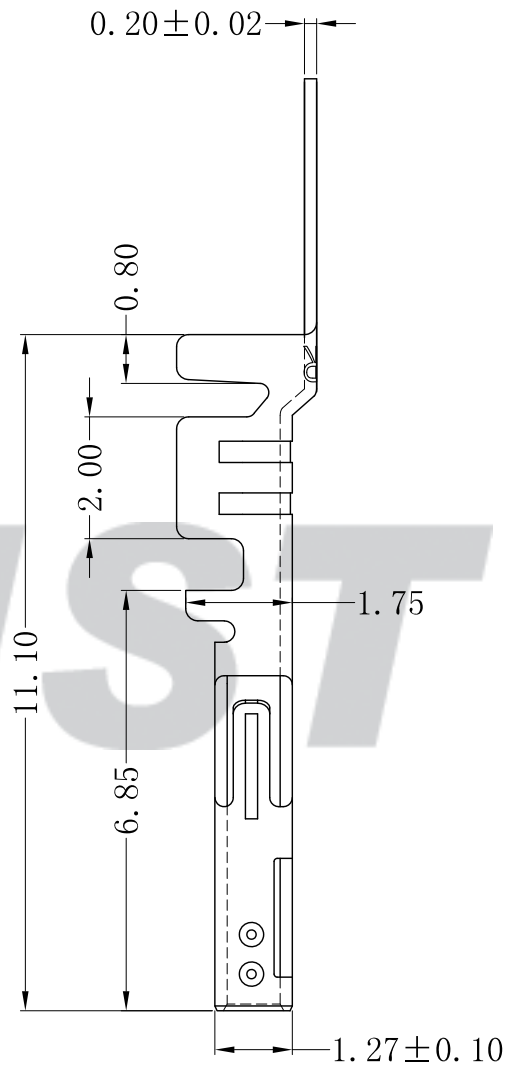
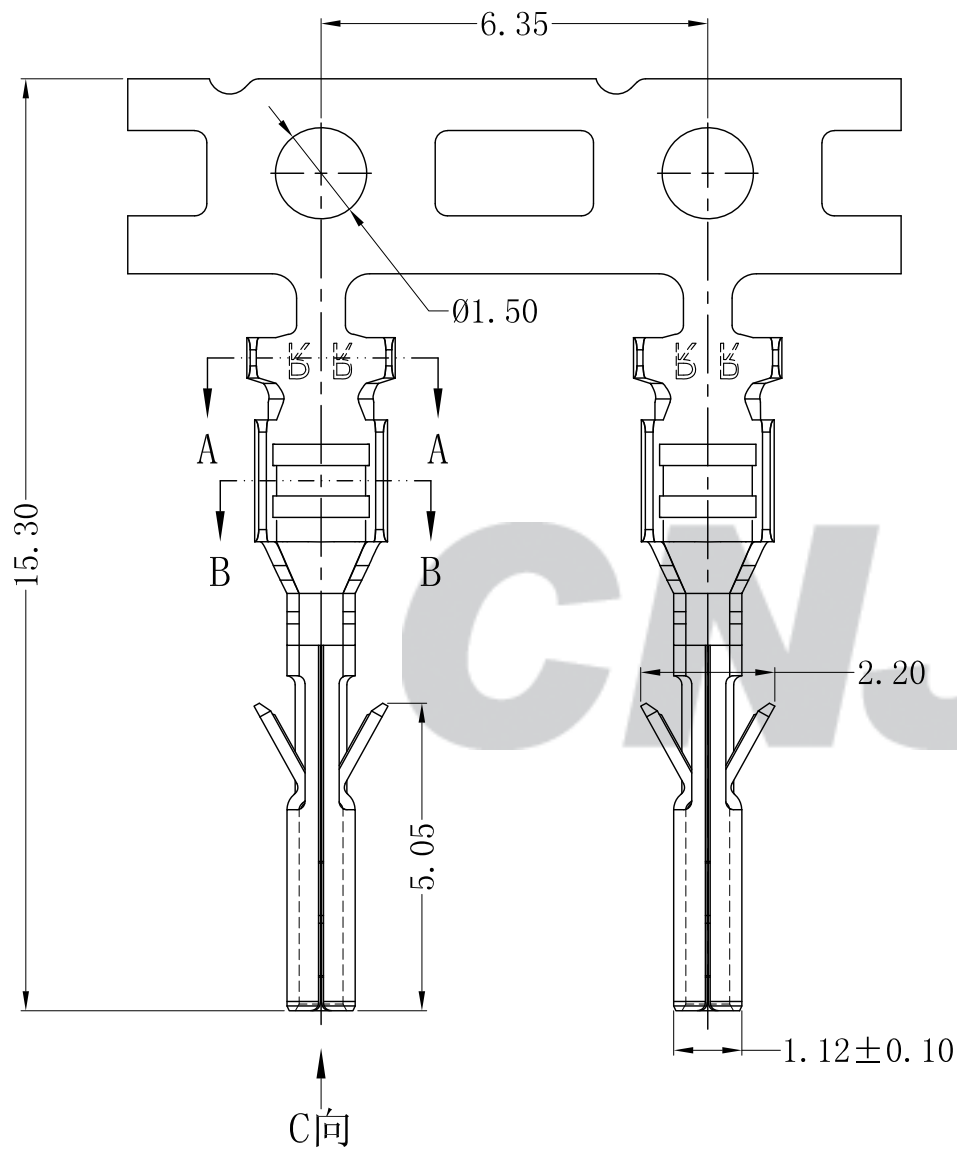
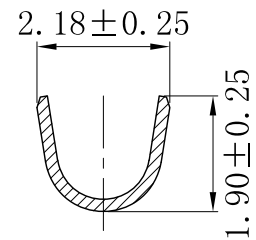

SECTION B-B

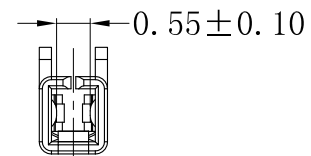

C向

专利产品

注：建议客户优先选择我司公母端产品配套使用，若在没有使用我司公母端配套产品情况下，出现因产品不匹配的质量问题，我司将不承担任何风险及责任。

Tolerance	
X.X	±0.30
X.XX	±0.20
X.XXX	±0.10
Angle	±3.0°

**CNJST** 捷仕泰企业

Drawn: 王程伟 2022.12.14

Model No.: QC3001PT-PA-Z

Checked: 吴丹平

Model Name: 3.00mm PITCH TERMINAL

Approved: 林旭芝

UNIT: mm

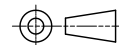

SCALE: FULL

REVISION: C/0

DWG NO. CNJST/GCDZ-0110

REV.	DATE	DESCRIPTION	APPD.	Wire Range	Insulation O.D.	QTY/Reel	Material	Plating
C/0	2022.12.14	更新模板	王程伟					
B/0	2020.10.23	NEW RELEASE		AWG #20~#24	1.85mm (Max)	10,000PCS	Phosphor Bronze	Tin-plated